

Vortex Flowmeter

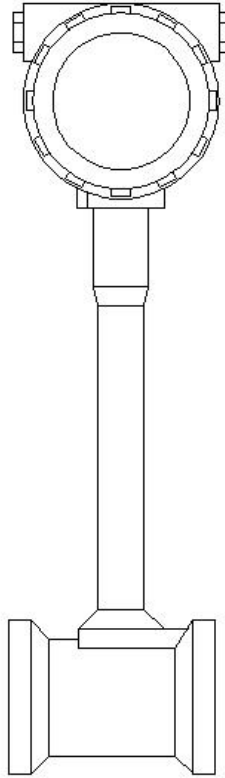

Installation and operation instruction

2020-5-Y

Contents

Foreword.....	1
I、 Product description.....	3
II、 Features.....	3
III、 Product structure and working principle.....	4
3.1 Product structure.....	4
3.2 Working principle.....	4
IV、 The main technical performance indicators.....	6
4.1 Basic parameter.....	6
4.2Vortex flowmeter accuracy class.....	6
4.3 Range of measurement.....	7
V、 Product classification and size.....	9
5.1Product classification.....	9
VI、 Product installation and use.....	12
6.1Instrument installation environment requirements.....	12
6.2 Installation requirements for instrument piping.....	12
6.3 Installation procedure of plug - in vortex street flow meter.....	15
6.4 Operation instructions of integrator.....	16
VII、 Routine maintenance.....	19
VIII、 Product FAQs and handling.....	19
Appendix1 485 communication protocol.....	21
Appendix 2 General Gas Density.....	22

Foreword

Thank you for purchasing vortex flowmeter independently developed and produced by our company.

The vortex flowmeter manual records how to use the product correctly and safely. Please read this manual carefully before installation and debugging in order to prevent the instrument from being damaged or unable to perform its best performance and ensure the stable operation of the instrument.

Step 1: open the box inspection must read

1. Check the packing list to see whether the accessories are complete.
2. Appearance inspection to see if the instrument is complete and damaged due to transportation;
3. Power test. If the battery is powered up, turn on the switch to check the display state of the meter.
4. Check whether the installation accessories are complete and prepare for installation.

Step 2: read the installation steps

1. Choose an appropriate installation environment. The ambient temperature should be -20-55°C, and the ambient humidity should be within the range of 5%-90%. See 6.1 installation environment requirements for the instrument for details;
2. Welding the product accessories, instruments should not be online welding (flange clamping instrument), Online welding may cause sensor thermal damage;
3. Purge the pipeline to ensure that there is no residual welding slag in the pipeline;
4. Install the instrument, pay attention to the direction sign of the instrument, prohibit reverse installation, ensure that the front and rear straight pipe meet the requirements, See installation requirements of instrument pipelines in 6.2 for details;
5. Open the front valve slowly to prevent air hammer or water hammer phenomenon from hurting the instrument;
6. Pipeline pressure test and leak detection to ensure that the pipeline does not leak;
7. Air tightness test to ensure that the installation instrument meets the sealing requirements;
8. Slowly open the back end valve to ensure stable flow field of medium passing through;
9. Instrument for normal operation;

10. Installation environment should avoid violent vibration, vibration environment will lead to unstable flow or static flow. In the case of slight vibration, pipe fastening device can be installed at the upstream and downstream 2D position, and soft connection can be installed at the connection place with the fan and other equipment.

11. The installation diagram of vortex flowmeter is as follows:

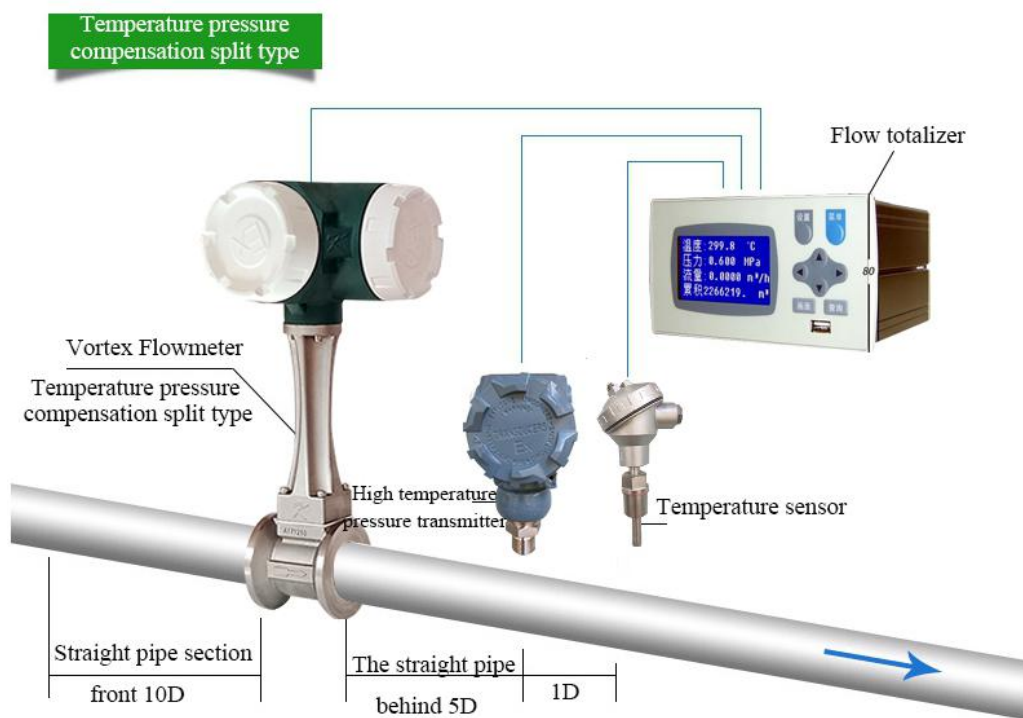

Note: the above installation drawings of high-end l-shaped vortex street products are for reference only.

I、 Product description

LUGB vortex flow meter is a kind of velocity flow meter, which is designed based on Karman vortex principle. It is mainly used for flow measurement of medium and fluid in industrial pipelines, such as flow control and measurement of gas, steam or liquid and other media.

LUGB vortex flow meter can achieve the following functions according to the selection: measuring the temperature, pressure, instantaneous flow and cumulative flow of medium fluid in industrial pipelines, and has pulse output, 4-20mA analog signal output, RS485 communication (Modbus RTU protocol), GPRS of Internet and other functions.

Vortex flow meter is widely used in heat supply, gas supply, chemical industry, environmental protection, metallurgy, textile, steel, pharmaceutical, paper making, drainage and other corporations to superheated steam and saturated steam, compressed air and gas (oxygen, nitrogen, hydrogen, natural gas, coal gas, etc.), water and liquid (such as: water, gasoline, alcohol, stupid class, etc.) of the measurement and control.

II、 Features

- The main body of the product has no moving parts, high reliability, long-term stability, simple structure and easy maintenance.
- The output of the sensor is the pulse frequency, and its frequency is linear with the actual flow of the measured fluid, there is no drift at zero, and the performance is very stable.
- The structure forms are various, including pipe type, plug type flow sensor and so on.
- The measurement accuracy of conventional liquid is $\pm 1.0\%$. The accuracy of the gas measurement was $\pm 1.5\%$;
- The pressure loss is small (about 1/4 to 1/2 of orifice flowmeter), which belongs to energy-saving flow meter;
- Flexible installation mode, can be horizontal, vertical or inclined to different angles according to different process pipeline;
- Circuit adopts a variety of protection mode, anti-surge, strong adaptability;
- High precision probe, piezocrystalline vortex sensor, stable signal. The 316L stainless steel sensor shell has strong corrosion resistance and good intercrystalline corrosion resistance. It also has good corrosion resistance to alkali solutions and most organic and inorganic acids;
- Long life lithium battery: equipped with 3.6v high poly lithium battery, with high storage energy density, the service life of more than 1 year;

- Products high and low temperature adaptability, environmental protection and other advantages;
- Wide measuring range, measuring range ratio up to 1:10-25;
- Within a certain Reynolds number range, the output signal frequency is not affected by the physical properties and component changes of the fluid, and the instrument coefficient is only related to the shape and size of the vortex generator , There is no need to compensate when measuring the volume flow rate of the fluid condition.

III、 Product structure and working principle

3.1 Product structure

The basic structure of LUGB series vortex flowmeter is shown in figure 1. It is mainly composed of shell, vortex generator, flow sensor, temperature sensor, pressure sensor, shield bar, integrator and other main accessories.

- 1.Integrating instrument
- 2.Pressure transducer
- 3. Shielding rod
- 4.shell

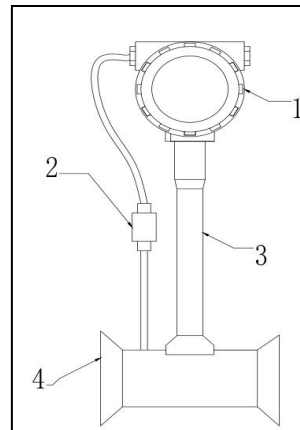

LUGB vortex flowmeter product structure drawing

3.2 Working principle

Vortex flowmeter is a speed-type flowmeter produced according to karman's vortex principle, which can be used for the measurement and metering of conventional gas, steam and liquid.Vortex flow sensor has high precision and wide range ratio, no moving parts in use, which can improve mechanical stability and reduce maintenance.Vortex flowmeter is almost not affected by the temperature, pressure and composition of medium when measuring the volume of working condition. Therefore, it is convenient to calibrate the instrument, so vortex flow meter is widely used in production and life.

When a trigonal column vortex generator is set in the fluid, regular vortices are generated alternately on both sides of the vortex generator, which is called Kármán vortex. The vortex columns are arranged asymmetrically downstream of the vortex generator. Vortex flowmeter is produced according to this principle. Vortexes are generated by generating bodies and the number of vortexes is detected by high-sensitivity sensors. In a certain range, the number of vortexes generated is proportional to the flow rate.

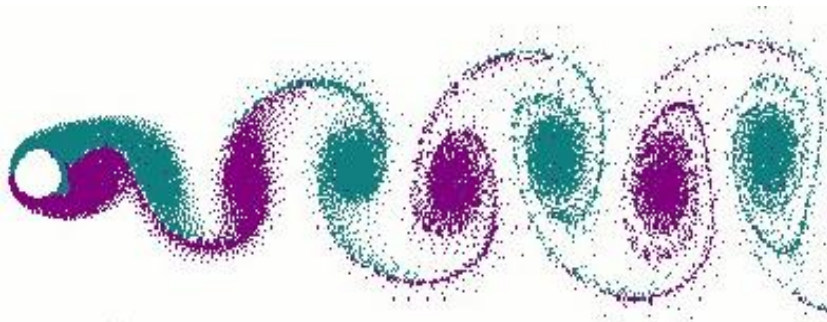

In vortex flowmeter, the relationship between flow rate and the number of vortexes generated can be expressed by the following formula:

$$Q = \frac{3600f}{K}$$

Q : Operating volume flow of the measured medium, The unit is m³/h.

f : Frequency of the number of vortices produced by the generating body, The unit is Hz.

K : Refers to the calculated or calibrated flow coefficient, It represents how many frequency signals per cube, the coefficient is usually obtained by calibration.

The formula of standard table method calibration coefficient K:

$$K = \frac{\text{Checkedmeterflow}Q_s}{\text{Standard meter flow}Q_c} \times K_{\text{Coefficient of the checked meter}} \quad (\text{The formula can also be used for flow correction}) .$$

IV、 The main technical performance indicators

4.1 Basic parameter

Executive standard	《JB/T9249-2015 Vortex flow meter 》 ...
Nominal diameter (mm)	15、 20、 25、 32、 40、 50、 65、 80、 100、 125、 150、 200、 250、 300、 (300~1000plug-in)
Nominal Pressure (MPa)	DN15-DN200 4.0(>4.0 Supply agreement), DN250-DN300 1.6(>1.6Supply agreement)
Use condition	Operational temperature: Std: -40~100°C, KST-M: -40~250°C, KST-HC: -40~330°C(Agreement order); Environmental temperature: -20°C~55°C, Relative humidity: 5%~90%, Atmospheric pressure: 86~106kPa
Material	Body: 304(Other materials are supplied by agreement) Integrator housing: Die Casting Aluminum.
Allowable vibration acceleration	piezoelectric type:0.2g
Accuracy	±1%R, ±1.5%R; Plug-in: ±2.5%R,
Rangeability	1: 6~1: 25
Supply voltage	sensor: DC +24V; transducer: DC +24V; battery-powered: 3.6Vbattery
Output signal	Pulse output; 4~20mA current、 RS485 (modbus- RTUagreement) and so on
Pressure loss factor	JB/T9249 standard $C_d \leq 2.4$
Explosive-proof	The Ann model: Ex ia II CT4
IP Grade	IP65
Couduit entry	Inside threadM20*1.5or other
Applicable medium	Gas,liquids ,steam
Transmission distance	Three-wire pulse output: $\leq 300m$, Two-wire standard current output (4~20mA) $\leq 1500m$; load resistance $\leq 500\Omega$; RS485 $\leq 1200m$.

4.2Vortex flowmeter accuracy class

Accuracy class		1	1.5	2	2.5
Maximum impact error	$q_t \leq q < q_{max}$	±1.0%	±1.5%	±2.0%	±2.5%
	$q_{min} \leq q < q_t$	±2.0%	±3.0%	±4.0%	±5.0%

Note: The bounded flow is $0.2q_{max}$

4.3 Range of measurement

The measuring flow range of different calibre instrument will be different, the instrument selection process must be in accordance with the flow range to choose the instrument, the most taboo is to choose the instrument according to the thickness of the pipeline. The biggest disadvantage of selecting instrument according to pipeline is that it is easy to cause measurement error due to insufficient flow.

The determination of the flow range of vortex flowmeter is based on the flow rate in operating conditions. Therefore, the flow rate is converted into the flow rate in operating conditions and the flow range table is compared to make the commonly used flow rate in the middle range measured by the instrument as far as possible.

4.3.1 reference condition

1. Gas :Normal pressure and temperature air, $t=20^{\circ}\text{C}$, $P=101.325\text{kPa}$ (AP) , .

2. Liquid:Normal temperature water, $t=20^{\circ}\text{C}$,

Reference range of vortex flow sensor under reference condition

Meter diameter (mm)	Liquid		Gas		
	Range of measurement (m ³ /h)	Range of output frequency(Hz)	Range of flow(m ³ /h)	Range of output frequency(Hz)	Extended range (m ³ /h)
15	0.5~5	35~600	3~10	300~1240	3~13
20	0.6~10	29~420	6~24	220~1250	6~30
25	1.2~12	21~210	9~48	190~1140	8.8~52
32	1.5~15	15~150	10~100	156~1080	10~170
40	2.5~25	13~130	27~150	140~1040	27~205
50	3.5~45	9~119	40~320	94~1020	35~380
65	5.5~75	6.7~91	60~480	94~910	60~700
80	8.5~110	5.3~68	90~720	55~690	86~1100
100	16~180	5.2~58	150~1050	42~536	133~1700
125	25~270	4.3~49	200~2200	38~475	150~2800
150	35~350	3.3~33	350~2500	33~380	347~4000
200	65~650	2.6~26	600~4000	22~315	560~8000
250	95~950	1.9~19	900~7000	18~221	890~11000
300	150~1500	1.8~18	1400~11000	16~213	1360~18000
(300)	150~1500	5.5~87		85~880	1560~15600
(400)	180~3000	5.6~87		85~880	2750~27000
(500)	300~4500	5.6~88		85~880	4300~43000

(600)	450~6500	5.7~89		85~880	6100~61000
(800)	750~10000	5.7~88		85~880	11000~110000
(1000)	1200~17000	5.8~88		85~880	17000~170000
>(1000)	Agreement				Agreement

Note: In Chart(300)~(1000)diameter is plug-in.

Working condition of traffic:Refers to the measurement of the current volume of medium passing through the pipeline,Is the medium in the working state,For example, gas can be compressed. When there is pressure in the pipeline, the volume of compressed gas is the flow rate under the working condition.The flow rate will change as the working environment changes.

Standard of flow:Refers to the volume of the medium at standard atmospheric pressure and 0°C (or 25°C) standard, when compressed gas is released into the standard environment..The flow rate will change as the working environment changes.

Vortex flowmeter measures the working volume, and only after temperature and pressure compensation can the standard volume be obtained. Generally, when it is used for trade measurement, the volume of gas shall prevail, and the quality of steam shall prevail.

$$Q_{\text{Working condition of the volume}} = Q_{\text{volume}} \times \frac{0.101325}{P_{\text{gage pressure}} + 0.101325} \times \frac{273.15 + T_{\text{temperature}}}{293.15} \text{ (Operating condition and standard state conversion formula)}$$

V、 Product classification and size

5.1 Product classification

5.1.1 Classified by function:

1.Common on-site display vortex flowmeter integrates vortex flow sensor and flow integrator, and its main performance index reaches the leading level in China. It is an ideal instrument for petroleum, chemical, electrical, light industry, power heating and other industries.

2.Vortex flowmeter of temperature and pressure compensation type, which integrates vortex flow sensor and flow integrator, has the function of temperature and pressure compensation, and its main performance index reaches the leading level in China.

3.The split-type vortex flowmeter is installed separately from vortex flow sensor and flow integrator, with the function of split-type display, which can realize high-altitude installation and low-altitude display, providing convenience for meter reading in high-altitude installation.

5.1.2 Classified by installation mode:

1. Flange clamp type (clamping type) vortex flow meter
2. Flange-connected vortex flowmeter
3. Simple insert vortex flowmeter
4. Ball valve insert vortex flowmeter
5. Other special structures can be customized through communication with suppliers

5.2 Product size and pressure rating

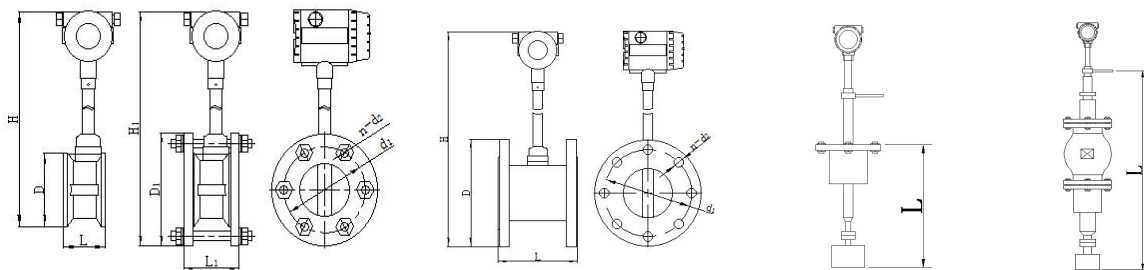

LUGB flange mounting diagram

LUGB flange connection diagram

Simple insertion diagram

Ball valve insertion diagram

Flange mounting common field display dimension

Table 1

Nominal diameter	Pressure rating MPa	L mm	L1 mm	D mm	D1 mm	H mm	H1 mm	d1 mm	d2 mm	n hole count
DN15	4	70	95	55	100	393	420	78	14	3
DN20		70	95	55	100	393	420	78	14	3
DN25		70	95	55	100	393	420	78	14	3
DN32		70	95	55	100	393	420	78	14	3
DN40		85	113	80	140	405	440	105	18	4
DN50		85	113	90	145	414	445	115	18	4
DN65	1.6	85	113	105	165	429	465	130	18	4
DN80		85	113	120	180	444	480	145	18	6
DN100		85	113	140	210	464	505	175	18	6
DN125		85	119	165	235	489	530	200	18	8
DN150		100	132	194	270	516	560	230	22	8
DN200		100	132	248	325	568	615	285	22	8
DN250		115	151	300	375	619	665	330	24	10
DN300	130	166	350	425	669	715	380	24	10	

Note:①The length L₁/L in the table is the size of the ordinary on-site display type below 250 °C, the temperature and pressure compensation size DN15-DN32 L₁/L₂ is increased by 15mm, and the other sizes are unchanged②The height H/H₁ common field display type in the table is below 250 °C, the temperature is 250~330 °C and the temperature and pressure compensation type height H/H₁ increases by 60mm±0.5.

Flange connection common field display dimension

Table 2

Nominal diameter(mm)	Pressure rating (MPa)	L mm	D mm	H mm	k mm	d2 mm	n hole count
DN15		170	95	413	65	14	4
DN20		170	105	418	75	14	4
DN25		170	115	423	85	14	4
DN32		170	140	435	100	18	4
DN40		170	150	438	110	18	4
DN50		170	165	455	125	18	4
DN65	1.6	190	185	473	145	18	8
DN80		190	200	490	160	18	8
DN100		200	220	509	180	18	8
DN125		200	250	537	210	18	8
DN150		200	285	569	240	22	8
DN200		200	340	622	295	22	12
DN250		240	405	681	355	26	12
DN300	240	460	735	410	26	12	

Note:The height H in the table is the size of the ordinary on-site display type, and the height H of the temperature and pressure compensation type increases by 60mm±0.5.

Insert general field display dimension

Table 3

Nominal diameter mm	Dielectric strength level MPa	Ball valve insert L mm	Simple insertion L mm
DN250	1.6	680	255
DN300		705	280
DN400		755	330
DN500		805	380
DN600		855	430
DN800-2000		905~1555	530~1130

VI、 Product installation and use

6.1 Instrument installation environment requirements

1.Flowmeter should be **installed in the indoor**, if installed in the outdoor, there should be cover above, in order to prevent rain invasion and the sun exposure and affect the service life of the flowmeter (flow meter wiring shielding wire to make a u-shaped, finally into the case when the line is from the bottom up, avoid rain along the road into the case);

2.The flow meter shall not be surrounded by strong external magnetic field interference, strong electrical equipment, high-frequency equipment, and avoid sharing power with these equipment;

3.Do not share power with inverter, welding machine and other polluting power equipment, and install purification power when necessary;

4.Avoid high temperature, cold, corrosive or extremely humid environment. If installation is necessary, protection of flow meter must be done;

5.The flowmeter should not be installed on the pipe with strong vibration. If it must be installed, pipe fastening device should be installed at 2D upstream and downstream, and anti-vibration pad should be added to enhance the anti-vibration effect.

6.Ample space should be left around the instrument installation point for installation wiring and regular maintenance.

6.2 Installation requirements for instrument piping

Vortex flow meter has certain requirements on the upstream and downstream straight pipe section of the installation point, otherwise it will affect the flow field of medium in the pipeline and affect the measuring accuracy of the meter. The length of the upstream and downstream straight pipe section of the instrument is required as shown in FIG. DN is the nominal diameter unit of the instrument :mm

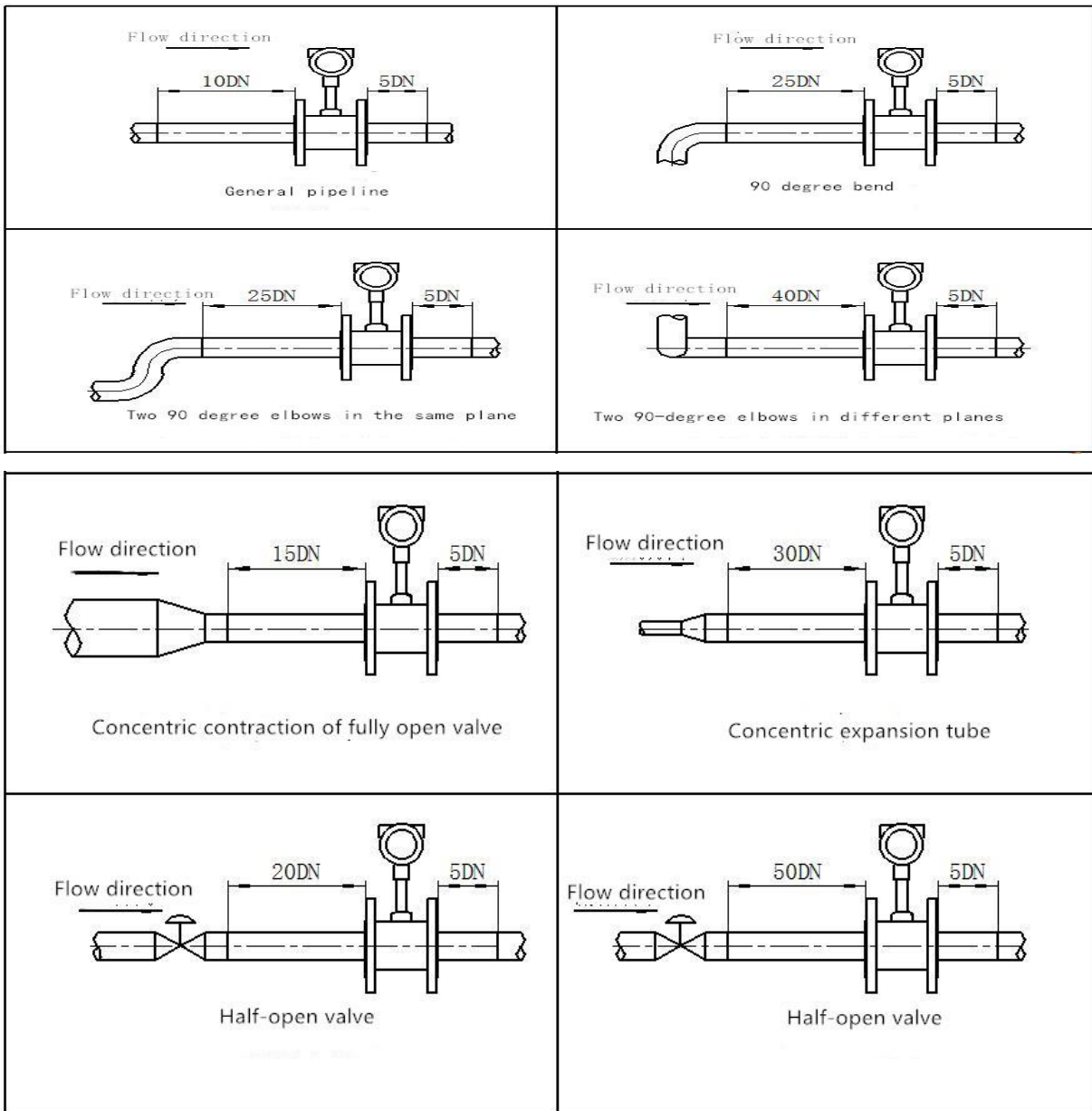

Note:

- 1、 As far as possible, the regulating valve should not be installed in the upstream of vortex street flow meter, but should be installed 10D beyond the downstream of vortex flow meter.
2. Inner diameters of upper and lower piping shall be the same. If there is any difference, the relationship between piping inner diameter D_p and vortex street meter inner diameter D_b should meet the following requirements: $0.98 D_b \leq D_p \leq 1.05 D_b$;
3. The upstream and downstream piping should be concentric with the internal diameter of flow meter, and the coaxiality between them should be less than $0.05 D_b$;
4. The sealing gasket between the meter and flange cannot be protruded into the pipe during installation, and its inner diameter should be 1-2mm larger than the inner diameter of the meter;

5. Installation design of pressure hole and temperature hole. When temperature and pressure transmitters need to be installed in the measured pipeline, the pressure measuring hole should be set at the downstream 3-5d and the temperature measuring hole should be set at the downstream 6-8d. D is the nominal diameter of the instrument, unit: mm;

6. The meter may be installed horizontally, vertically, or diagonally on the pipe.

7. When measuring gas, install the instrument in the vertical pipe with unlimited gas flow direction. However, if the pipe contains a small amount of liquid, in order to prevent the liquid from entering the gauge pipe, the airflow should flow from the bottom up, as shown in FIG. (iv) a;

8. When measuring liquid, in order to ensure that the tube is filled with liquid, the direction of liquid flow should be ensured from the bottom up when installing the instrument in the vertical or inclined pipeline. If there is a small amount of gas in the pipe, the instrument should be installed at the lower part of the pipe to prevent the gas from entering the measuring pipe, As shown in FIG. (iv) b.

9. Heat preservation measures should be paid attention to when measuring high temperature and low temperature media. The high temperature inside the converter (inside the watch head shell) should not exceed 70°C generally; Low temperature may cause condensation inside the converter, reduce the insulation impedance of the circuit board, and affect the normal operation of the meter.

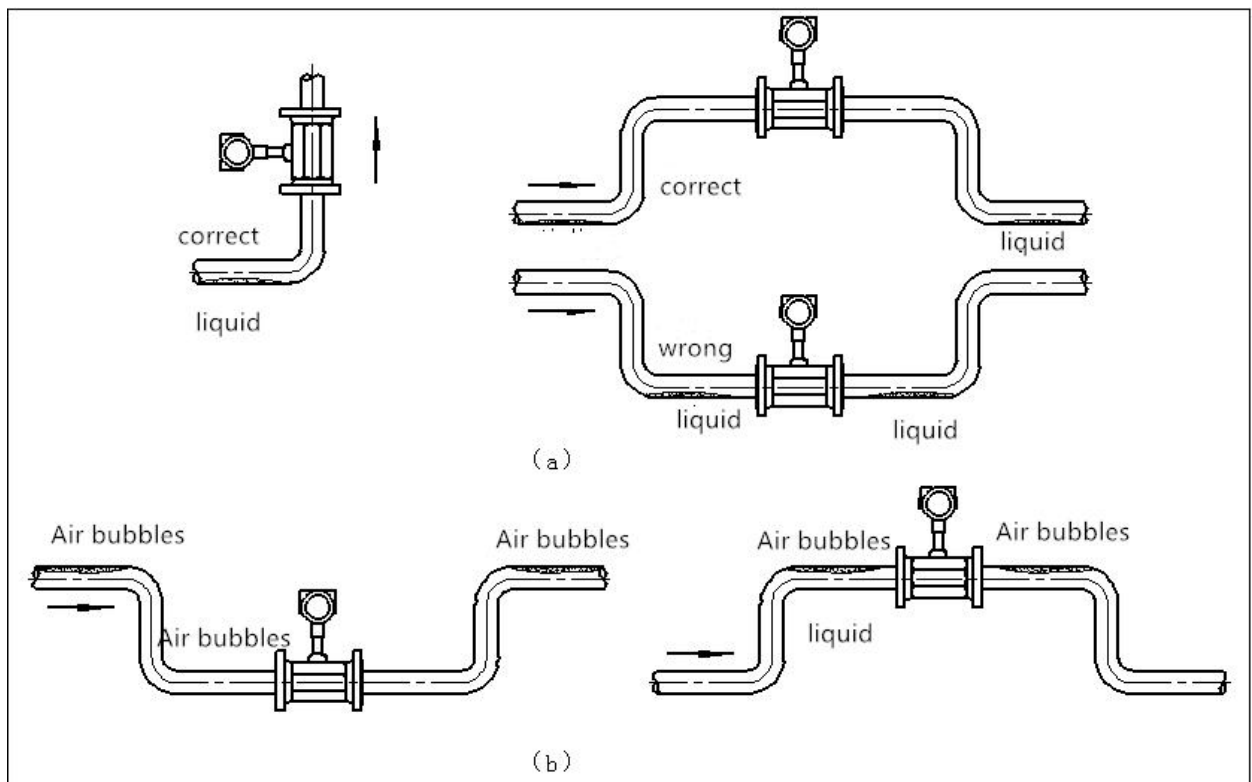

draw (IV)

6.3 Installation procedure of plug - in vortex street flow meter

1. A circular hole slightly smaller than 100mm with gas welding on the pipe, And the round hole around the burr clean, to ensure that the probe rotating smoothly;
2. Weld the flange provided by the manufacturer at the round hole of the pipe. The flange axis is required to be perpendicular to the pipe axis.
3. Install the ball valve and sensor on the welded flange;
4. Adjust the lead screw to make the insertion depth meet the requirements(ensure that the central axis of the probe and the central axis of the pipeline coincide),the flow direction of the fluid must be consistent with the direction indicated by the arrow;
5. Tighten the screws on the gland evenly.(note: the tightness of the gland determines the sealing degree of the instrument and whether the lead screw can rotate);
6. Check whether all links are completed, slowly open the valve to observe whether there is leakage(Special attention should be paid to personal safety)Repeat steps 5 and 6 if there is leakage.

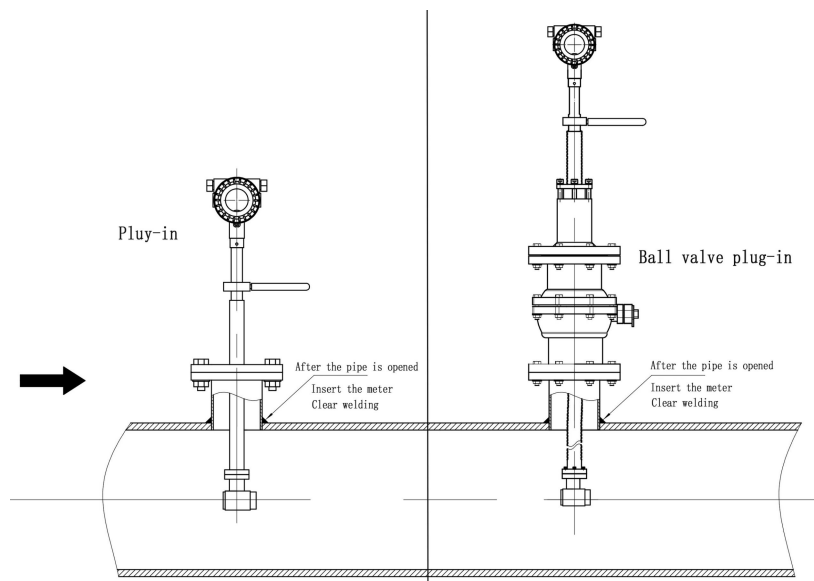

6.4 Operation instructions of integrator

1. Display interface description

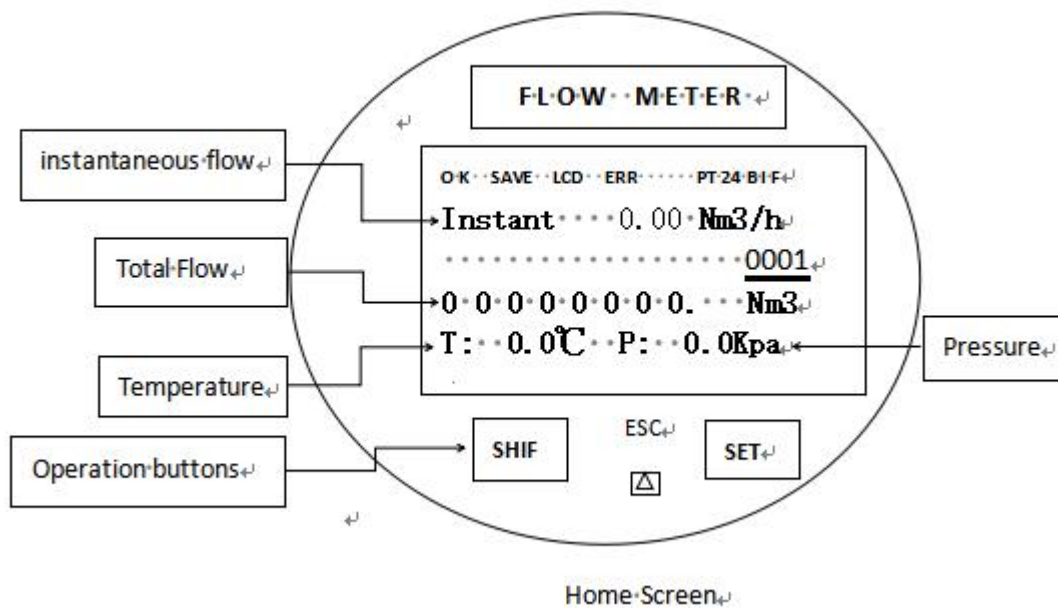

2. Circuit wiring diagram

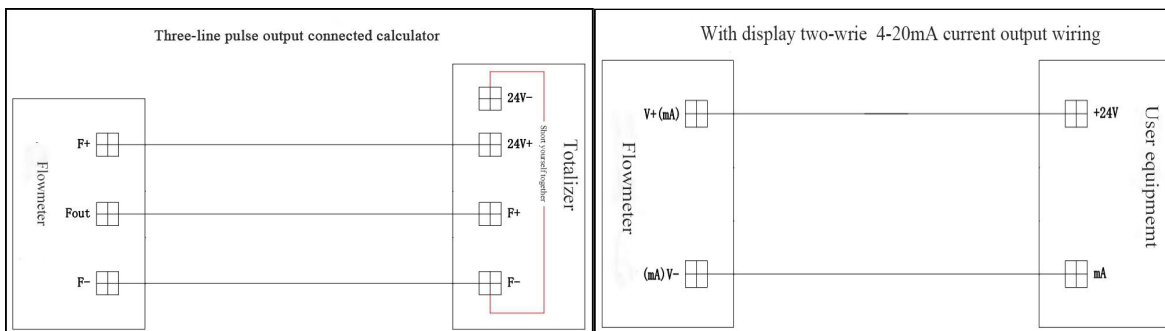
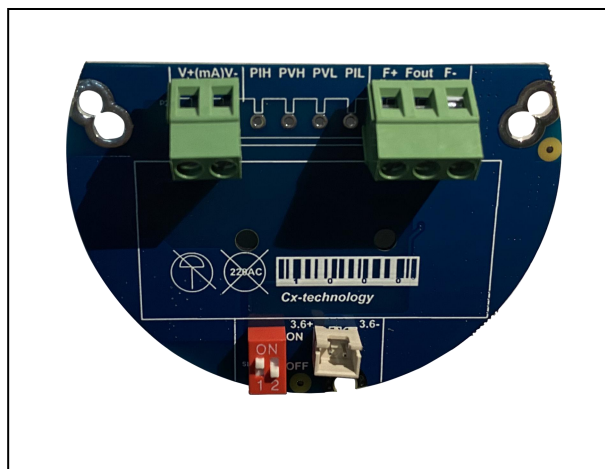

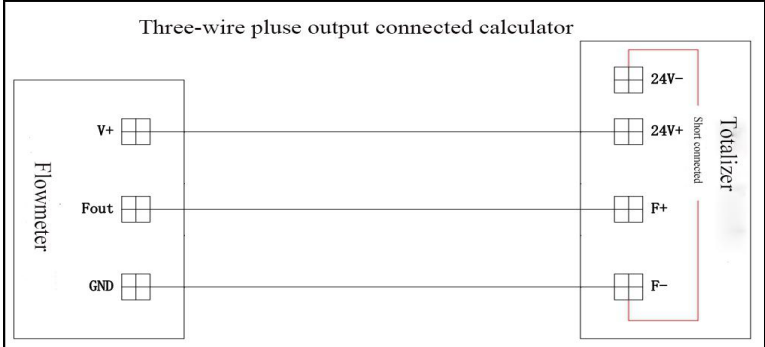
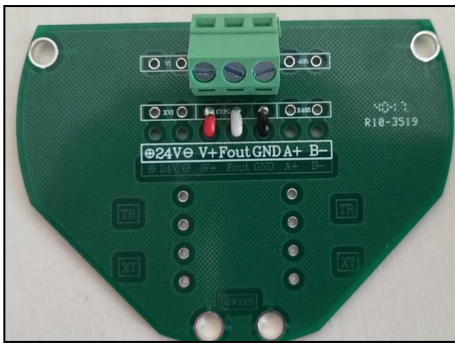
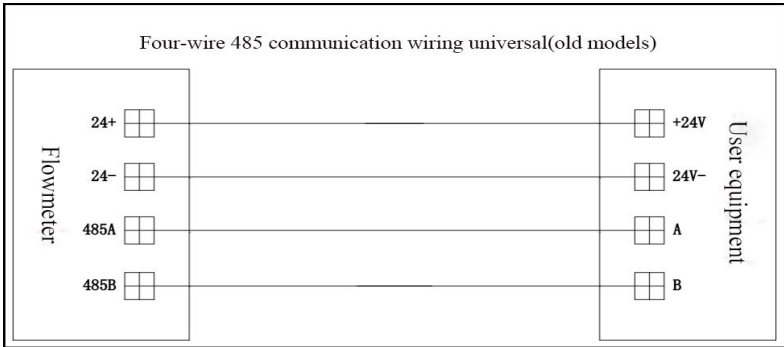
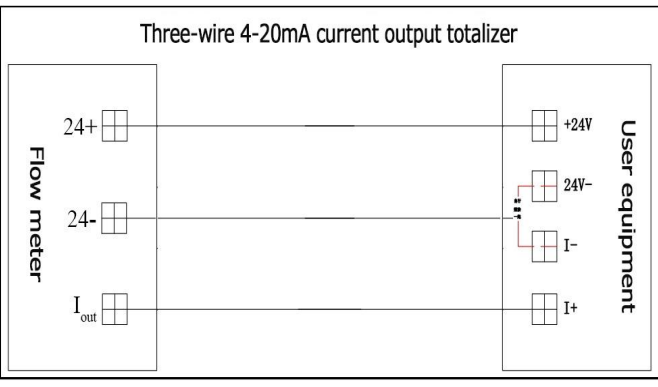
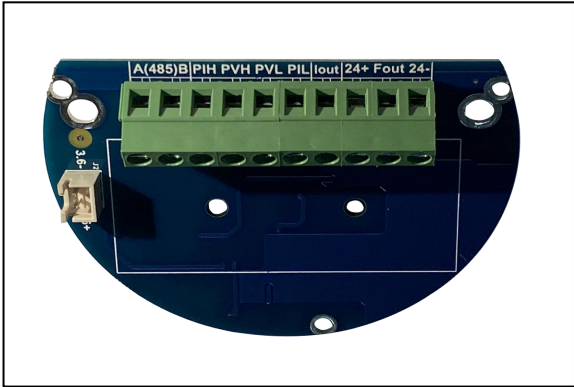
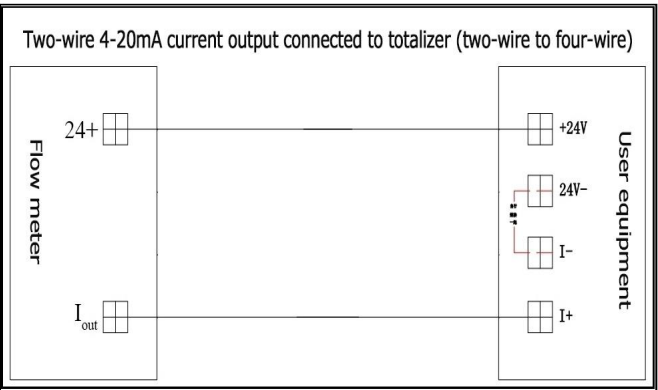
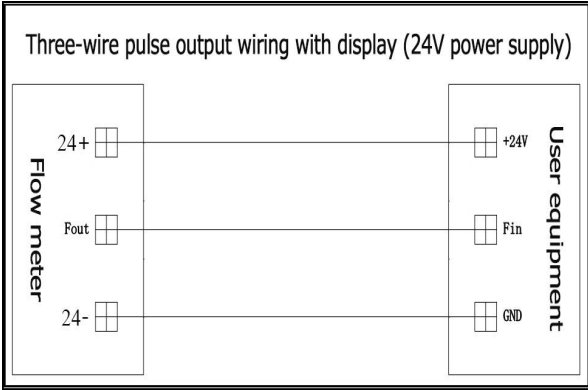

3. Instructions

① View frequency steps

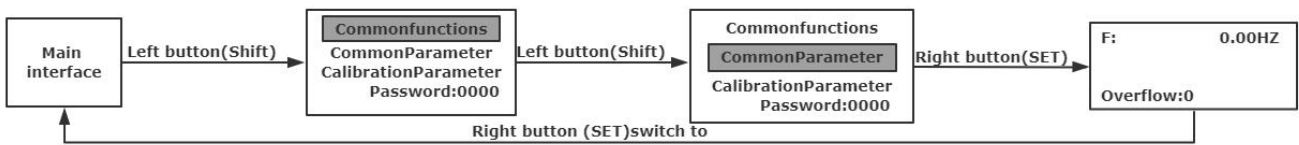

② Steps to change the unit, algorithm, coefficient, density, fullness and lower limit:

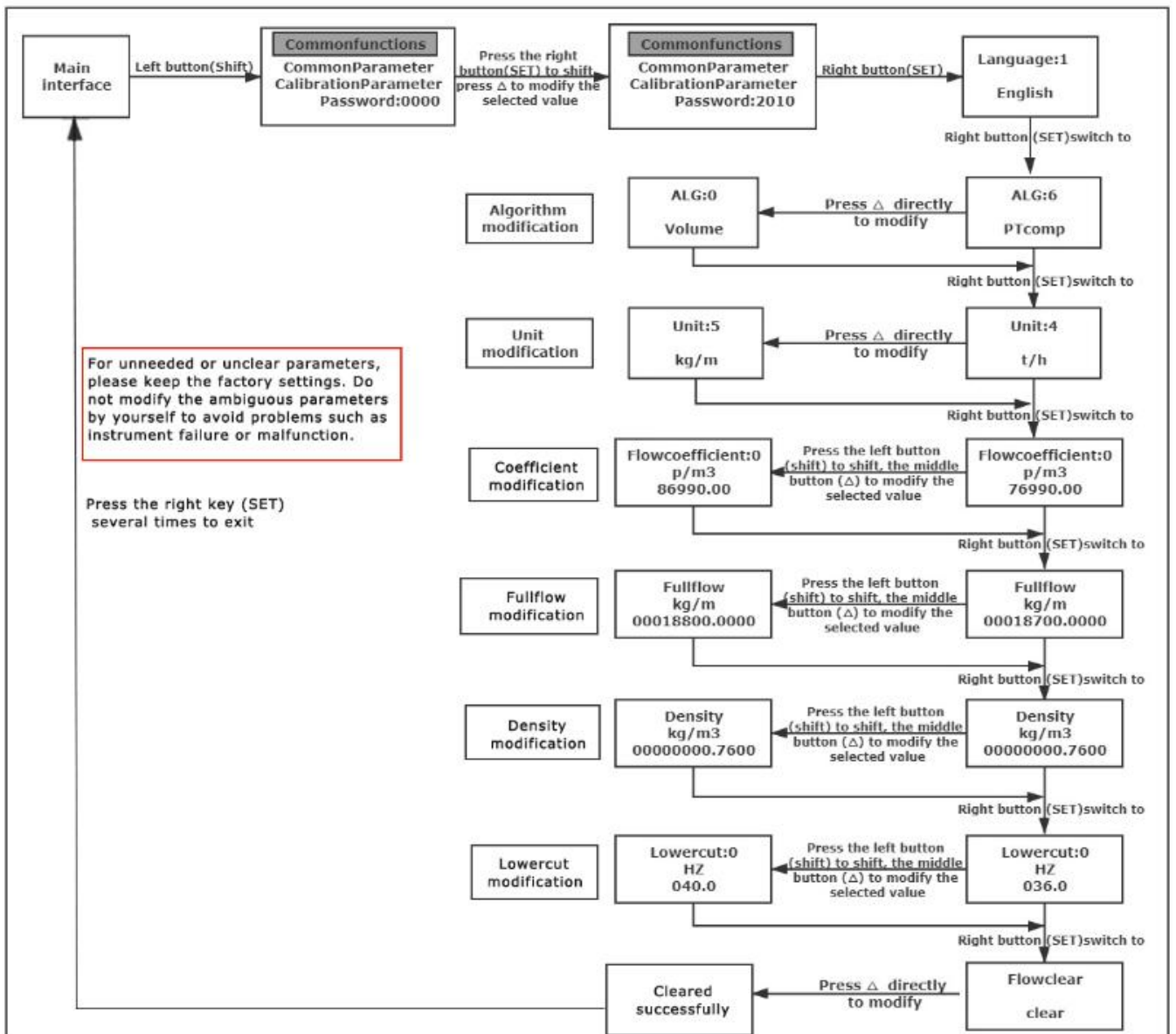

VII、 Routine maintenance

The vortex flowmeter is a high-precision measuring instrument, and there are always some wrong ways to reduce its service life during use. Nowadays, many users only know the use of the device, but they don't know that the device is the same as the person. It is very important to maintain it while using it. Our company has its own unique insights and rich experience in the daily maintenance of vortex flowmeters. In the spirit of high responsibility to customers, customers can enjoy the guidance and maintenance of experts after the after-sales service after purchase, so that customers have no any worries. I propose the following routine maintenance recommendations for vortex flowmeters for your reference:

1. Regularly clean, inspect and re-calibrate the vortex flowmeter. According to the national metrological verification regulations \leq JJG1029-2007 vortex flow meter \geq , the calibration period of the vortex flowmeter is two years.

2. Check the display meter, evaluate the meter reading, and check for any abnormalities.

3. Keep the filter unobstructed. The filter is blocked by impurities, and it can be judged from the increase of the difference of the pressure gauge reading at the inlet and the outlet, and the blockage is promptly eliminated, otherwise the flow will be seriously reduced.

4. When servicing the vortex flowmeter, the vortex generator and the probe body should be specially protected. When the fault is not clarified, it should not be dismantled at will, so as not to damage the probe body or damage the sealing performance, resulting in sensor leakage. If you encounter a fault that cannot be solved, you should contact the manufacturer for assistance.

VIII、 Product FAQs and handling

1. The amount of field instrument frequency change is large, and the elimination method is as follows:

2. A: First check whether the straight pipe section meets the requirements, and the gas can be relaxed to ensure the straight pipe section of the front 10D and the rear 5D. The straight pipe section does not meet the requirements, and the straight pipe section is not long enough. It is recommended to change the installation position. There may be electromagnetic interference at the scene. Method: Enhance the filtering function and lower the sensitivity by dialing the code switch. C. The on-site flow is too small, below the lower limit of the meter, For example, the 300-gauge plug-in gas has a

lower limit of 1500 m³/h, but the field indicates an instantaneous flow of about 500 m³. Since the flow rate is at the lower limit, the value does not change linearly. The flow rate can be increased by changing the meter factor (not recommended).D. A similar situation can occur when measuring the pulsating flow of a liquid.

3. There is 50Hz interference at the site, generally the shielded cable is not grounded.

4. No flow signal at the scene. A. The instrument small signal cut is too large, can be modified in the parameter setting; B. The power supply is not connected, no power; C. The flow rate is very low and the signal trigger point is not reached; the D.4-20mA output table is not set before leaving the factory.

5. The actual flow rate increases, but the meter display decreases, checking the cause of the site conditions (such as pipeline process, etc.).

6. The actual flow is reduced, but the meter display is increased, most of which is pipe vibration or the gasket is not at the center of the pipe during installation. The instrument should be reinstalled.

7. The meter display of the same working condition is inconsistent, and the difference is large. A. The customer's experience value is wrong, or the working conditions are different, such as the problem of the pipeline, the problem of the straight pipe, the problem of vibration, etc.;B. The parameters have been modified by the customer; C. The flow rate is too low, the lower limit is not linear; D. The temperature and pressure compensation table, the temperature pressure is faulty.

8. The instrument with 4-20mA output is inconsistent with the system display. A. The unit of parameter setting is inconsistent, or the range is not consistent; B.4-20mA output cable is too long (more than 1000 meters), and the loss is large.

9. The flow displayed by the meter differs greatly from the actual one, and most of the reason is the problem of the parameter setting unit.

10. Most of the static flow of the instrument is caused by vibration of the pipeline in the field. Damping measures or reducing the sensitivity of the instrument can be alleviated or eliminated.

Appendix1 485 communication protocol

The vortex circuit adopts the MODBUS-RTU protocol and only supports the 03th read command and does not support the write operation. The baud rate is 9600 and does not support other baud rates.

Mod bus Poll software RTU connection:

Display Option—Floating Pt (Data display format-floating point) ;

Command 03: HOLDING REGISTER (read holding register);

Device id: Internal address of the instrument;

Address: The starting address of the instrument parameter, from 1-14;

Length: Data length Length + Address <=14。

Parameter address: 40001—2:	Medium temperature, liquid turbine and thermal gas flow meter read this part is always 0;
40003—4:	Instantaneous flow;
40005—6:	Pressure (Mpa greater than 1000Kpa displayed on the LCD screen of the instrument, 485 communication unit is always Kpa);
40007—8:	frequency;
40009—10:	More than one hundred cumulative flow (1234) ;
40011—12:	Cumulative flow below the hundredth (87.89) ; Cumulative flow = 1234 × 100 + 87.89 = 123487.89;
40013 — 14 :	Current instantaneous flow usage unit(0: m ³ /h,1: L/m, 2:Nm ³ /h, 3:NL/m, 4:T/h, 5:Kg/m, 6:m ³ /m, 7:L/h, 8:Nm ³ /m, 9:Kg/h);

Appendix 2 General Gas Density

	Gas	Density (g / liter 0 ° C)		Gas	Density (g / liter 0 ° C)		Gas	Density (g / liter 0 ° C)
0	Air	1.2048	20	Trichloroethane C ₂ H ₃ Cl ₃	5.95	39	Helium Ne	0.9
1	Argon Ar	1.6605	21	Carbon monoxide CO	1.25	40	Ammonia NH ₃	0.76
2	Arsine AsH ₃	3.478	22	Carbon dioxide CO ₂	1.964	41	Nitric oxide NO	1.339
3	Boron tribromide BBr ₃	11.18	23	Cyanide C ₂ N ₂	2.322	42	Nitrogen dioxide NO ₂	2.052
4	Boron trichloride BCl ₃	5.227	24	Chlorine gas Cl ₂	3.163	43	Nitrous oxide N ₂ O	1.964
5	Boron trifluoride BF ₃	3.025	25	Helium D ₂	0.1798	44	oxygen O ₂	1.427
6	Borane B ₂ H ₆	1.235	26	Fluorine gas F ₂	1.695	45	Phosphorus trichloride PCl ₃	6.127
7	Carbon tetrachloride CCl ₄	6.86	27	Antimony tetrachloride GeCl ₄	9.565	46	Phosphatane PH ₃	1.517
8	Carbon tetrafluoride CF ₄	3.9636	28	Decane GeH ₄	3.418	47	Phosphorus PF ₅	5.62
9	Methane CH ₄	0.715	29	Hydrogen H ₂	0.0899	48	Phosphorus oxychloride POCl ₃	6.845
11	Ethylene C ₂ H ₄	1.251	30	Hydrogen bromide HBr	3.61	49	Silicon tetrachloride SiCl ₄	7.5847
12	Ethane C ₂ H ₆	1.342	31	Hydrogen chloride HCl	1.627	50	Silicon tetrafluoride SiF ₄	4.643
13	Propyne C ₃ H ₄	1.787	32	Hydrogen fluoride HF	0.893	51	Silane SiH ₄	1.433

14	Propylene C ₃ H ₆	1.877	33	Hydrogen iodide HI	5.707	52	Dichlorosilane SiH ₂ Cl ₂	4.506
15	Propane C ₃ H ₈	1.967	34	Hydrogen sulfide H ₂ S	1.52	53	Trichlorosilane SiHCl ₃	6.043
16	Butyne C ₄ H ₆	2.413	35	Helium He	0.1786	54	sulfur hexafluoride SF ₆	6.516
17	Butene C ₄ H ₈	2.503	36	Krypton Kr	3.739	55	sulfur dioxide SO ₂	2.858
18	Butane C ₄ H ₁₀	2.593	37	Nitrogen N ₂	1.25	56	Titanium tetrachloride TiCl ₄	8.465
19	Pentane C ₅ H ₁₂	3.219	38	Xenon Xe	5.858	57	Tungsten hexafluoride WF ₆	13.29